

8 7 6 5 4 3 2 1

D

C

B

A

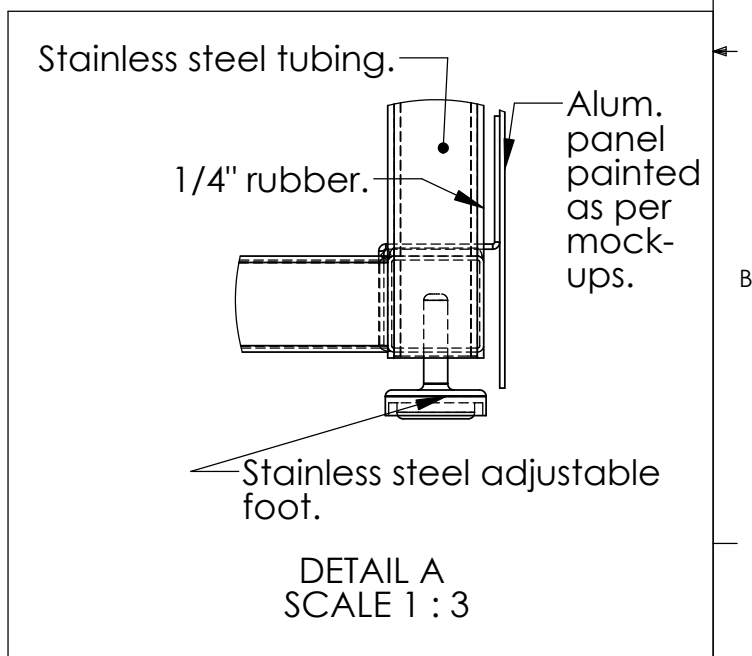
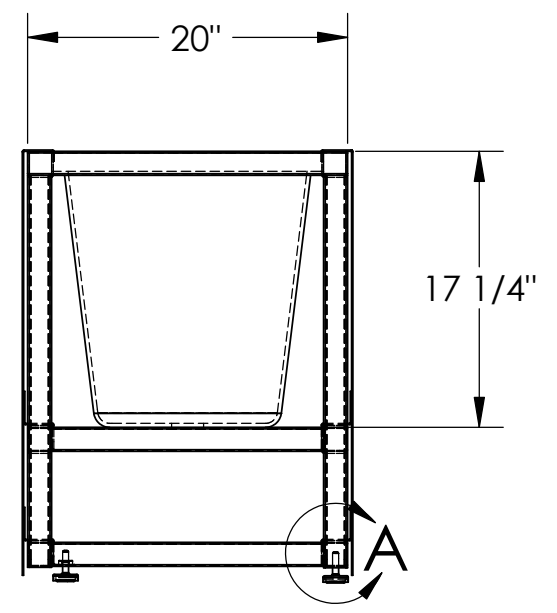
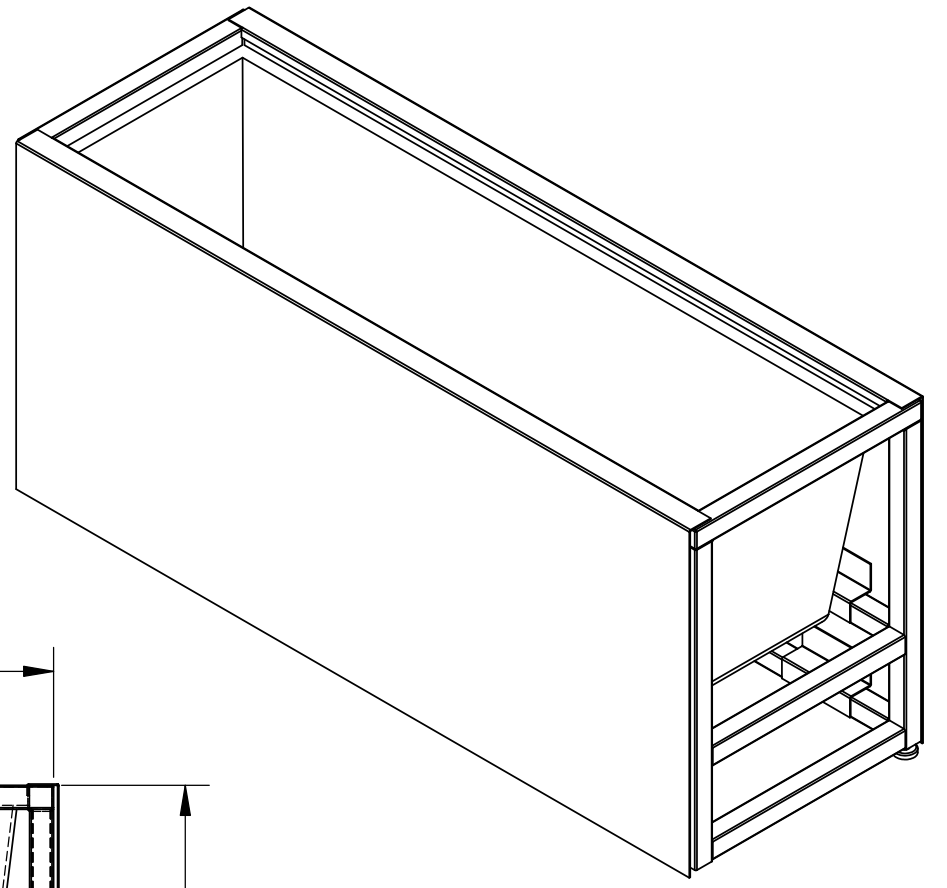
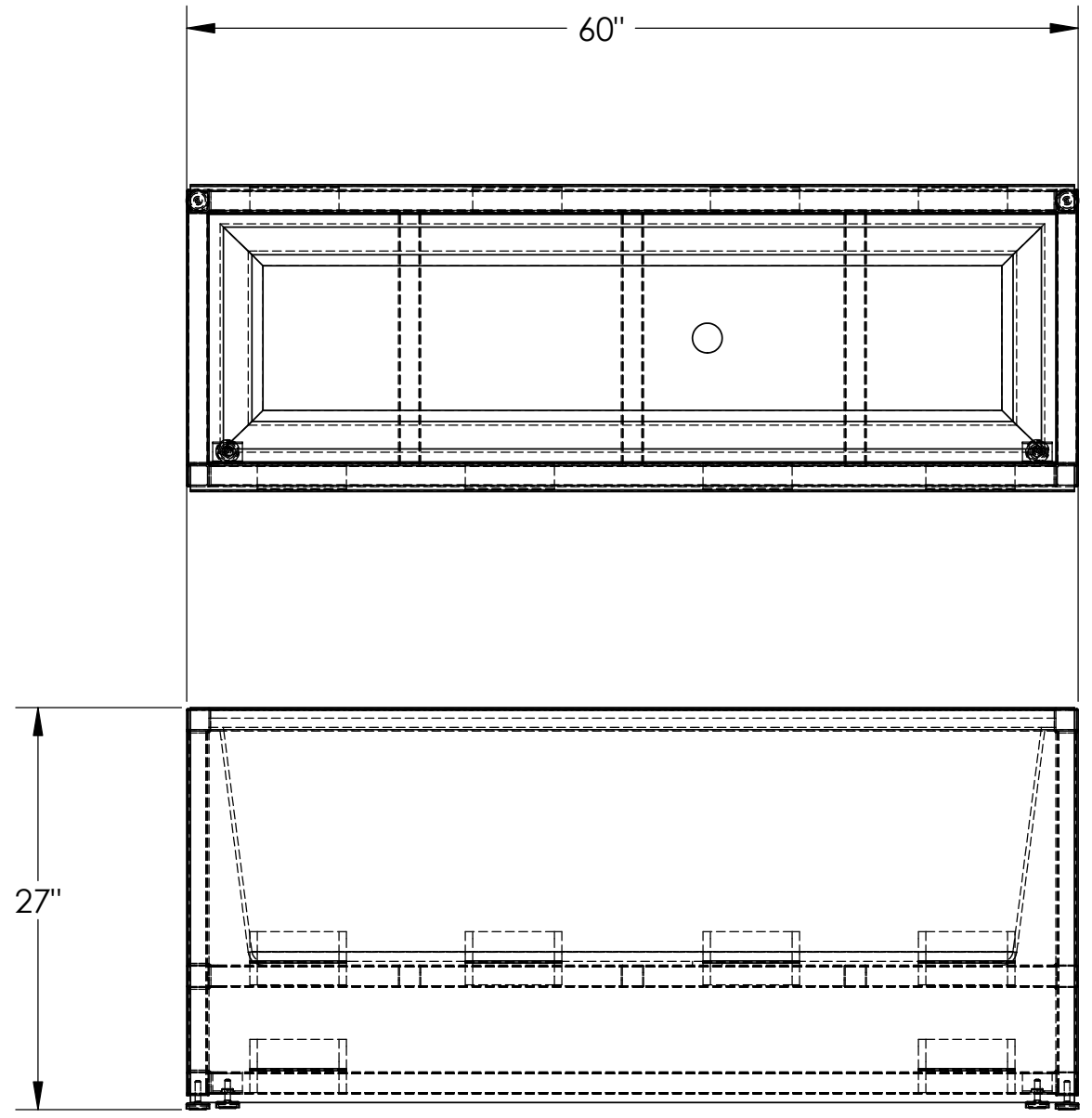

PLANTER DETAILS

- Frame is to be made of 16 gauge stainless steel with a mill finish.
- Aluminum panels are to be painted as per mockups.
- Front panels are .080 and rear panels are .060
- Any panel which is accessible to touch is to be made of .080
- Frames are to be bolted together during installation.
- Planters will follow slope of sidewalk.
- Planter liners are to be from Planter Technologies.
- Planter liners will have drain and hose installed.

PROPRIETARY AND CONFIDENTIAL
THE INFORMATION CONTAINED IN THIS DRAWING IS THE SOLE PROPERTY OF Custom Stainless Steel Inc. ANY REPRODUCTION IN PART OR AS A WHOLE WITHOUT THE WRITTEN PERMISSION OF Custom Stainless Steel Inc. IS PROHIBITED.

		UNLESS OTHERWISE SPECIFIED:		NAME	DATE
		DIMENSIONS ARE IN INCHES		DRAWN	
		TOLERANCES:		CHECKED	
		FRACTIONAL ±		ENG APPR.	
		ANGULAR: MACH ± BEND ±		MFG APPR.	
		TWO PLACE DECIMAL ±		Q.A.	
		THREE PLACE DECIMAL ±		COMMENTS:	
		INTERPRET GEOMETRIC TOLERANCING PER:		Frame is stainless. Panels are painted aluminum.	
		MATERIAL		SIZE	DWG. NO.
		FINISH		B	1.2
NEXT ASSY	USED ON			REV	
APPLICATION		DO NOT SCALE DRAWING		SCALE: 1:12	WEIGHT:
				SHEET 1 OF 1	

8 7 6 5 4 3 2 1